



INSTALLATION AND USER MANUAL

UNCONQUERED SUN WINDSOR SERIES PHOTOVOLTAIC MODULES

For further information:

Unconquered Sun Solar Technologies Inc.

www.unconqueredsun.com

Canadian Production Facility

11600 County Rd 42 Tecumseh, On N8N 2M1

PLEASE READ THIS MANUAL CAREFULLY BEFORE INSTALLING OR USING THE MODULES.

This manual contains important safety instructions for the PV module that must be followed during the installation and the maintenance of PV modules. Failure to follow these instructions may result in bodily injury or damage to property. Working on a photovoltaic system requires specialized knowledge and should only be attempted by qualified professionals.

Introduction

Thank you for choosing the UNCONQUERED SUN PHOTOVOLTAIC WINDSOR SERIES (PV) module. UNCONQUERED SUN is a world leader in the production of photovoltaic products. Our prime commitment is to produce quality products that will last for many years. Please familiarize yourselves with this manual before beginning to install the photovoltaic modules. These modules are listed to UL 1703. This manual contains safety information you need to be familiar with. **This manual does not constitute a warranty, expressed or implied. Unconquered sun does not assume responsibility and expressly disclaims liability for loss, damage, or expense arising out of or in any way connected with installation, operation, use or maintenance of PV modules. No responsibility is assumed by UNCONQUERED SUN for any infringement of patents or other rights of third parties that may result from use of PV modules. UNCONQUERED SUN reserves the right to make changes to the product, specifications or installation manual without prior notice.**

Manufacturer:

Unconquered Sun Solar Technologies Inc.
11600 County Rd 42 Tecumseh, On N8N 2M1

We reserve the right to make amendments

2010 Unconquered Sun Solar Technologies Inc.

Installation and User Manual

UNCONQUERED SUN Photovoltaic Modules

UNCONQUERED SUN 220, 230 and 240 Watt Windsor Series Panels

CONTENTS

| | |
|--------------------------------------|----|
| 1. WARNING NOTICES | 4 |
| 1.1 General Safety | 5 |
| 1.2 Handling Safety | 5 |
| 1.3 Installation Safety | 5 |
| 1.4 Site Selection | 6 |
| 1.5 Tilt Angle Selection | 6 |
| 1.6 Mounting Installation | 6 |
| | |
| 2. PV MODULE ELECTRICAL INSTALLATION | 8 |
| 1.7 Grounding | 8 |
| 1.8 Grounding Methods | 9 |
| | |
| 3. MAINTENANCE | 11 |
| 1.9 Specifications | 11 |

1. WARNING NOTICES



Danger of Death from Electric Shock

Photovoltaic modules can generate electricity when exposed to light. The voltage of single modules is less than 50 VDC, but when connected together in series, the total voltage can be dangerously high. When connected together in parallel the current is added together. When handling the module the following must be followed to avoid the risk of arcing, fire and electric shock.

1. The installation of PV should only be performed by qualified personnel.
2. Do not wear metallic jewellery when installing
3. Do not install PV modules when wet. Tools must be dry.
4. Do not use damaged or defective modules. Place all damaged or defective modules in a carton to avoid exposure to light. Even damaged or defective modules can produce electricity.
5. Contact with electrically active parts of a PV module such as terminal, can result in burns, sparks and lethal shock whether the PV modules are connected or not.
6. PV systems can produce high voltage and current which could present an increased hazard and may cause serious injury or death.
7. Artificial sunlight should not be concentrated upon the PV module. Do not expose PV modules to sunlight concentrated with mirrors, lenses or other means.
8. Use appropriate safety equipment (insulated tools, insulated gloves, etc) when working on any wiring.



Danger of death from electric shock

The inverter can produce dangerous high voltage.

1. Be sure to follow all manufacturers' instructions before installing any PV modules.
2. Use extreme caution when wiring or installing an inverter.
3. Be sure to shut down inverter before installing or removing PV modules.



Danger of death from electric shock

When exposed to light, PV modules produce direct current. When disconnecting any PV modules from a string, a deadly arc can occur.

1. Never remove a PV module without disconnecting the inverter from the grid.
2. Never remove the PV module without disconnecting the PV system from the inverter.
3. Make sure that the connectors are in good working condition and are properly connected to each other.

1.1 GENERAL SAFETY

1. All PV modules should be installed in accordance with applicable codes and regulations.
2. Roof mounted PV modules are to be mounted over a fire resistant roof.
3. Only PV modules with the same cell type and size should be connected in series.
4. Follow all safety precautions of other components used in the system.
5. Avoid uneven shade on the PV module surface. Shaded cells may become hot ("hot spot" phenomena) which may result in permanent damage to the module.
6. Do not use high pressure water spray or chemicals to clean the PV modules
7. Turn off the inverters and circuit breakers immediately, should there be a problem.

1.2 HANDLING SAFETY

1. Do not expose the PV module to excessive loads on the surface of the PV module or twist the frame. The glass may break.
2. Do not stand or step on the PV module. The glass may be slippery, and there is a risk of injury or electric shock if the glass is broken.
3. PV modules are heavy. Please handle with care.
4. Do not hit or put excessive load on the glass or back sheet. PV cells may break.
5. Do not twist the interconnect cable excessively.
6. Do not drill holes in the frame. It may compromise the frame strength and cause corrosion of the frame and will void the warranty.
7. Do not touch the PV module with bare hands. The frame of the PV module has sharp edges and may cause injury. Wear suitable gloves, such as leather gloves with padding in the palm and finger areas.
8. Do not drop the PV module or allow objects to fall on the PV Module.

1.3 INSTALLATION SAFETY

1. Always wear protective head gear, insulating gloves and safety shoes (with rubber soles).
2. Due to the risk of electrical shock, do not perform any work if the terminals of the PV module are wet.
3. Do not install PV modules in the rain, snow or windy conditions.
4. Insert Interconnect connectors fully and correctly. Check, all connections. Cables should be secured to the PV module frames, support structure or raceway to prevent movement. Keep connectors out of direct sunlight.
5. Do not touch the terminal box and the end of the interconnect cables with bare hands during installation or under sunlight, regardless of whether the PV module is connected to or disconnected from the system.
6. Do not unplug a connector if the system circuit is connected to an operating load.
7. Do not damage the back sheet of PV modules when mounting the PV modules.
8. Do not damage the surrounding PV modules or mounting structure when replacing the PV module.
9. Keep children away from the system when installing
10. Use UV resistant cable ties or other wire management hardware to secure the interconnect cables. Drooping cable may cause various problems, such as leading to electrical shorts.
11. When installing PV modules on roof or other structures, the appropriate safety practices and safety equipment should be used at all times to avoid injury.

1.4 SITE SELECTION

PV modules are intended for outdoor use only and not intended for use on any moving vehicles. In most applications UNCONQUERED SUN modules should be installed in a location where they receive the maximum sunlight throughout the year. In the Northern Hemisphere the modules will normally face south. In the Southern Hemisphere the modules will face North. Avoid trees, buildings or other obstacles that can cast shadows on the modules. Take proper steps in order to maintain reliability and safety in case the PV modules are installed in areas that have heavy snow/extreme cold/strong winds. Installations over, or near, water and areas where installations are prone to salt water exposure. If you are planning to use the PV modules where salt water damage may occur, please consult with UNCONQUERED SUN to determine an appropriate installation method, if installation is possible.

1.5 TILT ANGLE SELECTION

UNCONQUERED SUN modules produce the most power when the sun's rays strike the module perpendicular to the module surface. To avoid performance losses in series circuits ensure that all modules have the same tilt and orientation. Your solar professional will be able to determine the best tilt angle for your location.

1.6 MOUNTING AND INSTALLATION

There are several approved ways to mount the UNCONQUERED SUN modules to a support structure. They may be mounted in either portrait or landscape orientation using either the bolt holes provided or using frame clamps (not provided). For all mounting methods a minimum gap of $\frac{1}{4}$ " (7 mm) between modules is required to allow for thermal expansion. For roof mounted systems a minimum gap of 1" between the module and the roof surface is required to allow for ventilation.

The modules may be fastened to a support using the bolt holes in the bottom of the frame shown in Figure 1. The module should be fastened at four points, with a $\frac{5}{16}$ " (M8) bolt, washers and a nut (not provided).

Inter-module type or end-type clamps must be designed for PV modules and have minimum dimensions shown in Figure 2. and installed in accordance with the instructions below and drawings provided. The mounting clamps should be at least 1.5" (38 mm) long, at least 0.12" (3 mm) thick, and have a catch width of at least 0.2" (5mm). When installing, the clamp must overlap the support rail by at least 0.4" (10 mm) and be placed within the permissible clamping zones shown in Figure 3. For the high load situations shown in Figure 3 an additional center support rail should be used. Note that UNCONQUERED SUN does not warranty frame clamps. The UNCONQUERED SUN module warranty may be void if customer-selected frame clamps are improper or inadequate with respect to properties (including strength or material) or installation.

Figure (1) Attachment Using Mounting Holes

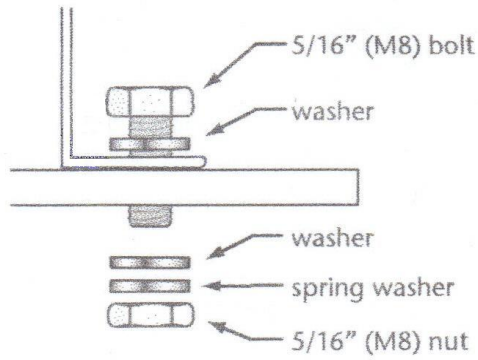

Figure (2) Attachment Using Clamps

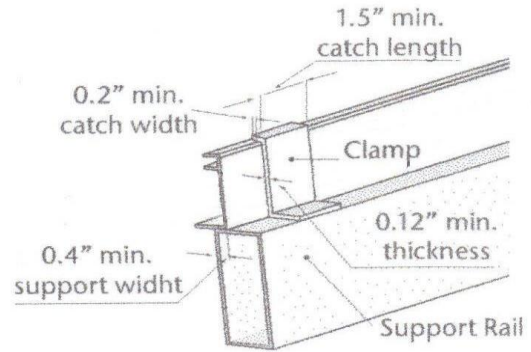
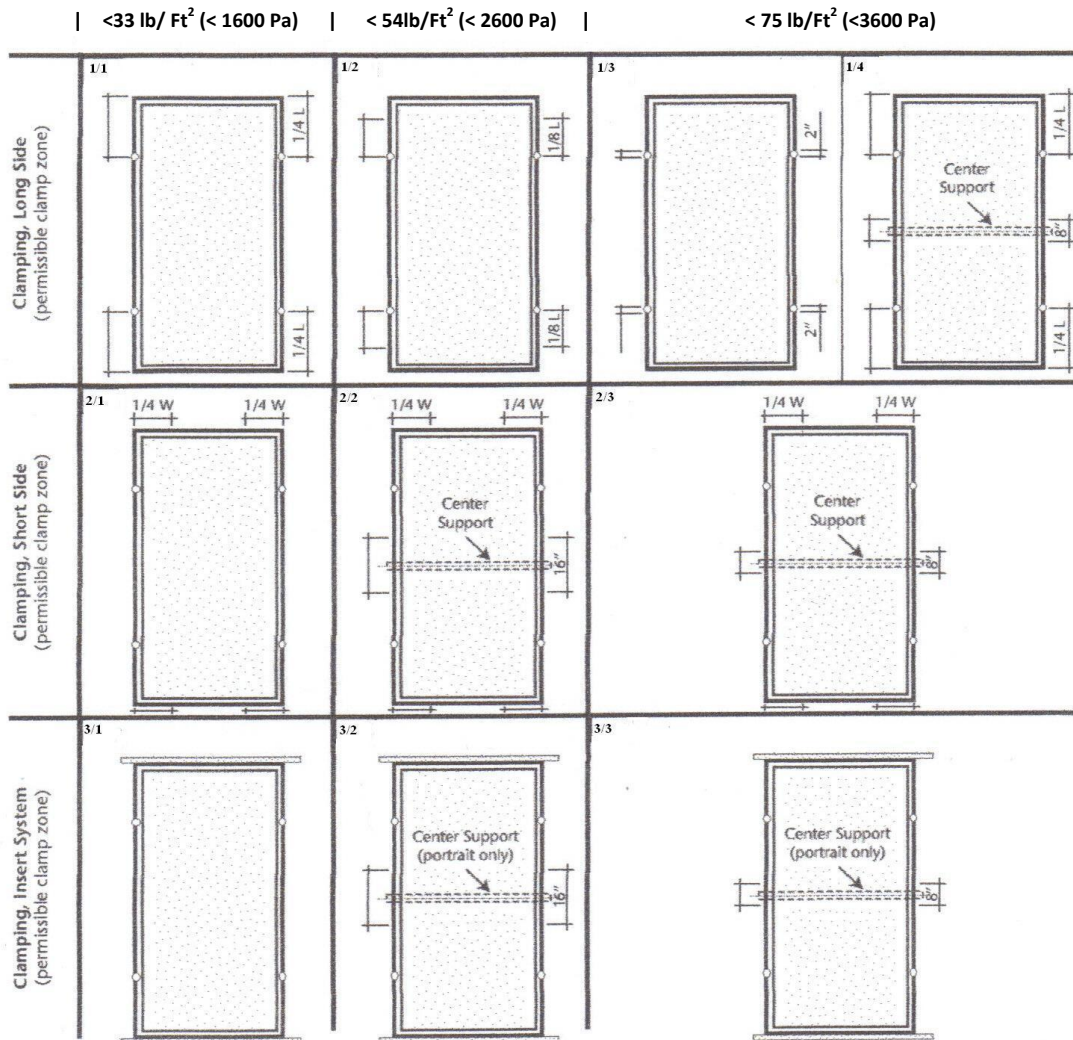

Figure (3) Attachment Guidelines (Permissible Clamping Zones) – Both Portrait and Landscape Options



2. PV MODULE ELECTRICAL INSTALLATION

All Unconquered Sun modules are pre-wired with (2) 4mm² PV1-F 90°C UL listed wire and terminated with MC4 connectors. This wire intended for interconnection wiring of grounded and ungrounded photovoltaic power systems as described in 690.31 (A). **Negative is indicated on connector, Positive is indicated on other connector. Make sure that all connections are not under load while being connected.** Care must be taken to arrange the system ground so that the removal of one module will not interrupt the grounding of the other modules. Under no circumstances should the junction box be opened. Series and parallel connections shall be made by use of #10 (or 4mm²) AWG 90° C type sunlight resistant output cables (or equivalent) with Male and Female MC4 locking connectors. To comply with NEC 2008 – locking ring may be required.

Select a suitable conductor diameter to minimize voltage drop. Conductors should be between 8-14 AWG (1.5 – 10mm²) USE-2 (non conduit) THWN-2 (conduit) or check with your solar professional to determine correct conductor sizing or wire. Over current protection shall be in accordance to NEC 240.

NOTE: MAXIMUM SYSTEM VOLTAGE IS 600 VDC. All installations, string sizing and electrical connections should be designed to meet the relevant NEC codes. A qualified solar professional should refer to NEC 690-7(a) to determine the maximum number of UNCONQUERED SUN modules that can be placed in series. Under normal conditions, a photovoltaic module is likely to experience conditions that produce more current and/or voltage than reported at standard test conditions. Accordingly, the values of I_{sc} and V_{oc} marked on this module should be multiplied by a factor of 1.25 when determining component voltage ratings, conductor ampacities, fuses and the size of controls connected to the PV output. Refer to section 690-8 of the National Electrical Code for an additional multiplying factor of 125 percent (80% de-rating) which may be applicable.

2.1 GROUNDING

Several different methods of grounding can be used to provide the required connection through the frame. Before installation contact the local code Authority Having Jurisdiction (AHJ) to determine the proper grounding requirements. Attach all module frames to an earth ground in accordance with applicable articles of the National Electrical Code (NEC), 250 and 690.

- For listed devices, follow the instructions of the Grounding and Bonding Equipment manufacturer's installation instructions.
- Use the holes milled in the frame for grounding.
- When using grounding wire, select ground wire of copper, copper alloy or other suitable material no smaller than 14 AWG (2.1mm), sized accordingly for the photovoltaic system per NEC, and sized compatibly with the Grounding and Bonding Equipment manufacturer's installation instructions.

2.2 Grounding Methods

1) Grounding Lug with Machine Screw at Grounding Hole

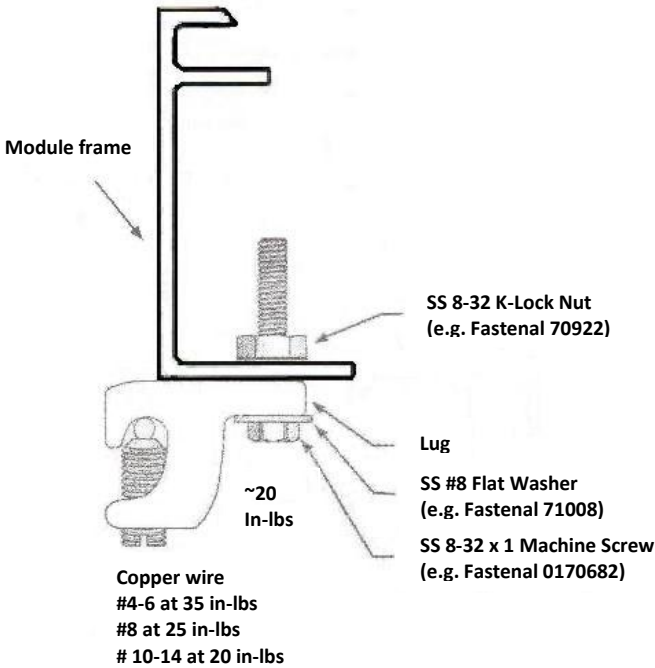

- Select a grounding lug listed for direct burial and outdoor use (tin-plated, solid copper lay-in lug with a stainless-steel set screw) capable of accepting a 4-14 AWG copper conductor, e.g. ILSCO GBL4-DBT, Burndy CL50-1TN.
- Use an emery cloth, sandpaper, or a steel brush to clean the frame. The area cleaned should be the same size as the lug mating face. Apply an anti-oxidation coating, e.g. Burndy Penetrox, Ideal Noalox.
- To the grounding hole, secure the lug with stainless steel hardware consisting of a machine screw (min #8), a flat washer, and a lock nut, as shown in the figure. Tighten the nut to approximately 20 in-lbs.
- Tighten the lug set screw to the copper wire at the torque specified by lug manufacturer.

2) Grounding Lug with Machine Screw at Mounting Hole

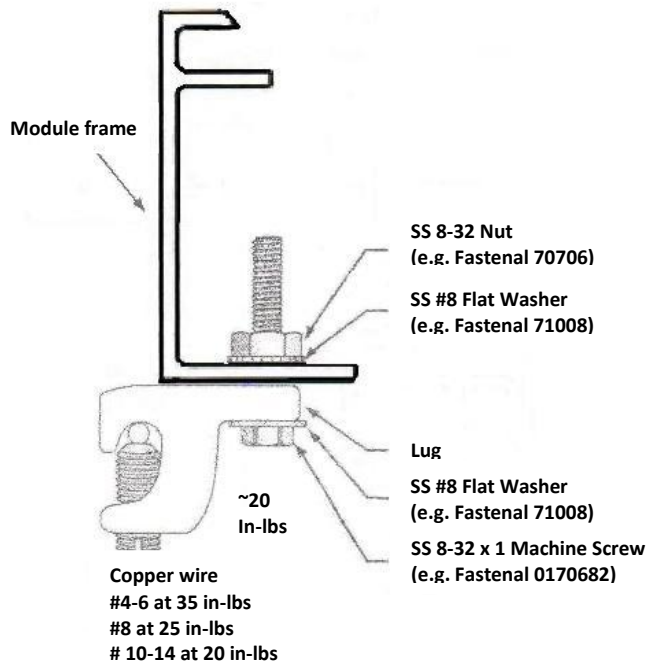

- Select a grounding lug listed for direct burial and outdoor use (tin-plated, solid copper lay-in lug with a stainless-steel set screw) capable of accepting a 4-14 AWG copper conductor, e.g. ILSCO GBL4-DBT, Burndy CL50-1TN.
- Use an emery cloth, sandpaper, or a steel brush to clean the frame. The area cleaned should be the same size as the lug mating face. Apply an anti-oxidation coating, e.g. Burndy Penetrox, Ideal Noalox.
- To the mounting hole, secure the lug with stainless steel hardware consisting of a machine screw (min #8), two flat washers, and a nut, as shown in the figure. Tighten the nut to approximately 20 in-lbs.
- Tighten the lug set screw to the copper wire at the torque specified by lug manufacturer.

3) Grounding Lug with Thread-Cutting Screw at Grounding Hole

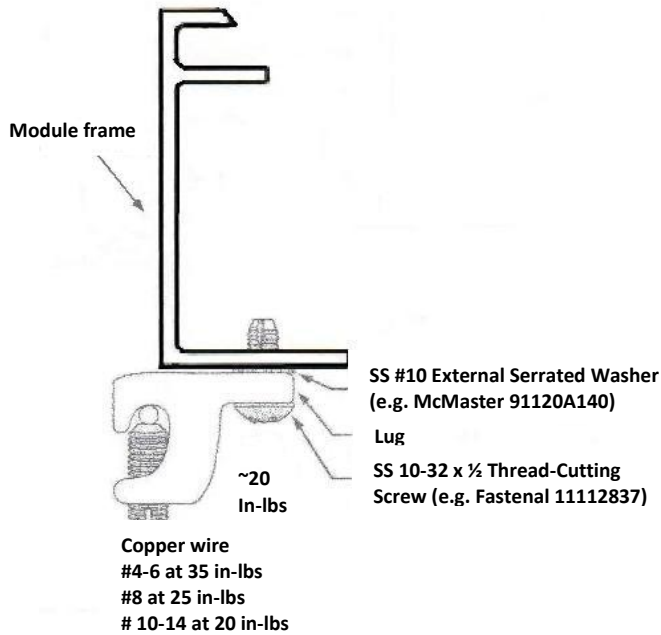

- Select a grounding lug listed for direct burial and outdoor use (tin-plated, solid copper lay-in lug with a stainless-steel set screw) capable of accepting a 4-14 AWG copper conductor, e. g. ILSCO GBL4-DBT, Burndy CL50-1TN.
- Use an emery cloth, sandpaper, or a steel brush to clean the frame. The area cleaned should be the same size as the lug mating face. Apply an anti-oxidation coating, e.g. Burndy Penetrox, Ideal Noalox.
- To the grounding hole, secure the lug with stainless steel hardware consisting of a thread-forming/thread-cutting screw of at least 32 threads per inch and an external serrated washer. Tighten the screw until the serrated washer has penetrated the frame, approximately 20 in-lbs.

4) Grounding Clip at Grounding Hole

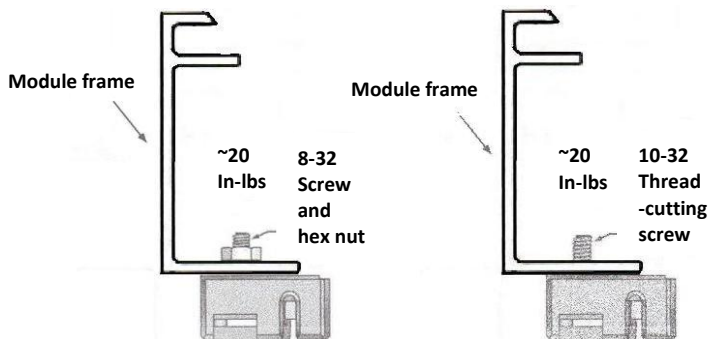

- Select a grounding clip listed and designed to ground photovoltaic modules.
- To the grounding hole, secure the clip per manufacturer's instructions and tighten the screw to 20 in-lbs.
- Insert copper wire into the wire slot per manufacturer's instructions.

3. MAINTENANCE

UCONQUERED SUN PV modules are designed for a long life and require very little maintenance. If the angle of the PV module is 5 degrees or more, normal rainfall is usually sufficient to keep the module glass surface clean under most weather conditions. If dirt build-up becomes excessive, clean the glass surface only with a soft cloth using water. Do not use high pressure spray or chemicals to clean the modules. If cleaning the back of the module is necessary, take the utmost care not to damage the backside materials. In order to ensure proper operation of the system, please check all wiring connections and the condition of the wire insulation periodically.

3.1 SPECIFICATIONS

| | WINDSOR 220™ | WINDSOR 230™ | WINDSOR 240™ |
|------------------------------------|------------------|-----------------|-----------------|
| Maximum Power (P_{max}) | 220W | 230W | 240W |
| Open Circuit Voltage (V_{oc}) | 36.6V | 37.0V | 37.4V |
| Short Circuit Current (I_{sc}) | 8.33A | 8.40A | 8.65A |
| Maximum Power Voltage (V_{pm}) | 30.0V | 30.0V | 30.1V |
| Maximum Power Current (I_{pm}) | 7.66A | 7.67A | 7.98A |
| Maximum System Voltage | 600V | 600V | 600V |
| Series Fuse Rating (A) | 15A | 15A | 15A |
| Weight | 17.7 kg/39.0 lbs | 17.7kg/39.0lbs | 17.7kg/39.0lbs |
| Length | 1644mm/64.72" | 1644mm/64.72" | 1644mm/64.72" |
| Width | 972mm/38.26" | 972mm/38.26" | 972mm/38.26" |
| Depth | 50mm/1.96" | 50mm/1.96" | 50mm/1.96" |
| Maximum Load | 50psf/2400Pa | 50psf/2400Pa | 50psf/2400Pa |
| Temperature Coefficients | | | |
| P_{max} | -0.485%/°C | | |
| V_{oc} | -0.351%/°C | | |
| I_{sc} | +0.053%/°C | | |

The electrical characteristics are within ±10% of the indicated values of I_{sc} , V_{oc} , and P_{max} under Standard Test Conditions (irradiance of 100 mW/cm², AM 1.5 spectrum, and a cell temperature of 77°F (25°C).